

Gujarat Arts and Science College, Ahmedabad

Books/chapters and papers published during last five year

Sl. No.	Name of the teacher	Title of the book/chapters published	Title of the paper	National / International	Calendar Year of publication	ISBN number	Link
1	Dr.Fahmeeda F.Shaikh	Globalisation and Sustainable Development:Dynamics of Trade,Industry and Society	A statistiactal analysis on consumer preception towards online shopping	International	2020	978-93-89652-97-0	-----
2	DR. SAMIR GIRISHKUMAR PANDYA	12th National Science Symposium 2020	SMART HOME SYSTEM USING ARDUINO	National	2020	978-81-929521-5-4	https://www.researchgate.net/publication/346658530_SMART_HOME_SYSTEM_USING_ARDUINO
3	Dr.Fahmeeda F.Shaikh	An Applications of Statistical Models in Water Management Studies	-----	National	2020	978-93-87861-19-0	-----
4	Dr.Fahmeeda F.Shaikh	Operation Research: Techniques for Management	-----	National	2020	978-93-88996-42-6	-----
5	Dr.Fahmeeda F.Shaikh	Role of Multidisciplinary Studies in Environment Protection	Bayesian Estimation and Prediction for Exponentiated logistic Distribution based on upper Records	International	2020	978-93-88996-23-5	-----
6	Dr.Fahmeeda F.Shaikh	Women in Higher Education: Context, Challenges and Courage	Gender Equality as a Challenge for Higher Education in India	National	2020	978-81-8152-518-5	-----
7	Dr. Bharti G. Oza	Nayee kahani ke pariprekshya mein Bishma sahani ki kahaniyon ka adhyayan	-----	-----	2020	978-93-84748-17-3	-----
8	Jaykumar Buddhdev	An International Multidisciplinary Research E-Journal	"Understanding the Modern Pandemics through AIDS Poetry: A Comparative Study"	International	2020	ISSN No. 2454-8596	https://myvedant.com/wp-content/uploads/79-JAYKUMAR-BUDDHDEV-FINAL.pdf
9	Dr.Fahmeeda F.Shaikh	Operation Research: Techniques for Management	-----	National	2020	978-93-87861-19-0	-----

GLOBALIZATION AND SUSTAINABLE DEVELOPMENT:

Dynamics of Trade, Industry and Society

Dr. NILAM PANCHAL



Himalaya Publishing House

ISO 9001:2015 CERTIFIED

Globalization and Sustainable Development: Dynamics of Trade, Industry and Society

Dr. Nilam Panchal

MBA, PGDIRPM, M.Phil., Ph.D., D.Litt.

FDP (IIMA), SFDP(IIMA)

Associate Professor,

*B. K. School of Professional & Management Studies,
Gujarat University, Gujarat.*



Himalaya Publishing House

ISO 9001:2015 CERTIFIED

© Editors

No part of this publication may be reproduced, stored in a retrieval system, or transmitted in any form or by any means, electronic, mechanical, photocopying, recording and/or otherwise without the prior written permission of the editors and the publisher.

First Edition : 2020

ISBN: 978-93-89652-97-0

Information contained in this work has been received from respective research scholars/ paper authors. For information published herein, The Editor, **B.K. School of Professional and Management Studies, Gujarat University, Gujarat, India** and **Himalaya Publishing House Pvt. Ltd.** are not responsible. Authors are solely responsible for any damages arising out of use of this published information work.

- Published by** : Mrs. Meena Pandey for **Himalaya Publishing House Pvt. Ltd.**,
"Ramdoot", Dr. Bhalerao Marg, Girgaon, Mumbai - 400 004.
Phone: 022-23860170, 23863863; **Fax:** 022-23877178
E-mail: himpub@bharatmail.co.in; **Website:** www.himpub.com
- Branch Offices** :
- New Delhi** : "Pooja Apartments", 4-B, Murari Lal Street, Ansari Road, Darya Ganj,
New Delhi - 110 002. **Phone:** 011-23270392, 23278631; **Fax:** 011-23256286
- Nagpur** : Kundanlal Chandak Industrial Estate, Ghat Road, Nagpur - 440 018.
Phone: 0712-2721215, 3296733; **Telefax:** 0712-2721216
- Bengaluru** : Plot No. 91-33, 2nd Main Road, Seshadripuram, Behind Nataraja Theatre,
Bengaluru - 560 020. **Phone:** 080-41138821; **Mobile:** 09379847017,
09379847005
- Hyderabad** : No. 3-4-184, Lingampally, Besides Raghavendra Swamy Matham, Kachiguda,
Hyderabad - 500 027. **Phone:** 040-27560041, 27550139
- Chennai** : New No. 48/2, Old No. 28/2, Ground Floor, Sarangapani Street, T. Nagar,
Chennai - 600 017. **Mobile:** 09380460419
- Pune** : "Laksha" Apartment, First Floor, No. 527, Mehunpura,
Shaniwarpeth (Near Prabhat Theatre), Pune - 411 030.
Phone: 020-24496323, 24496333; **Mobile:** 09370579333
- Lucknow** : House No. 731, Shekhupura Colony, Near B.D. Convent School, Aliganj,
Lucknow - 226 022. **Phone:** 0522-4012353; **Mobile:** 09307501549
- Ahmedabad** : 114, "SHAIL", 1st Floor, Opp. Madhu Sudan House, C.G. Road, Navrang Pura,
Ahmedabad - 380 009. **Phone:** 079-26560126; **Mobile:** 09377088847
- Ernakulam** : 39/176 (New No. 60/251), 1st Floor, Karikkamuri Road, Ernakulam,
Kochi - 682 011. **Phone:** 0484-2378012, 2378016; **Mobile:** 09387122121
- Cuttack** : New LIC Colony, Behind Kamala Mandap, Badambadi,
Cuttack - 753 012, Odisha. **Mobile:** 09338746007
- Kolkata** : 108/4, Beliaghata Main Road, Near ID Hospital, Opp. SBI Bank,
Kolkata - 700 010. **Phone:** 033-32449649; **Mobile:** 07439040301
- DTP by** : **SRI SIDDHI SOFTTEK**
Bengaluru
- Printed at** : Trinity Academy, Mumbai. On behalf of HPH.

CONTENTS

- Foreword
- Acknowledgement
- Prologue

SECTION 1: CONTEMPORARY ISSUES IN FINANCE

- | | | |
|-----|---|---------|
| 1. | A Study on Investment Objectives of Salaried Class Investors of Selected Districts of Gujarat
<i>Kinjal Patel, Prof. (Dr.) Tejash Pujara</i> | 1 – 10 |
| 2. | Analysis of Solvency Position of Selected Indian IT Sector Companies in Context with Pearls Analysis
<i>Dr. Dharmikkumar Nikulbhai Dave</i> | 11 – 15 |
| 3. | Benefits of Developing Rupee Derivatives in IFSC Opportunities, Benefits & Challenges (An Exploratory Study for IFSC, India)
<i>Dipesh Shah, Dr. Pawan K. Chaugan</i> | 16 – 29 |
| 4. | Holistic Performance Assessment of Indian Private sector Banks: An Empirical Study with Multiple Model Approach
<i>Sundarka Baibhav, Dr. Nilam Panchal</i> | 30 – 41 |
| 5. | A Study on Goods and Services Tax (GST) Structure and Issues
<i>Chauhan Rakeshkumar Gunvantbhai, Dr. Margie Parikh</i> | 42 – 47 |
| 6. | Development of Financial Services in India
<i>Prof. Jagdish D. Dhoriya</i> | 48 – 52 |
| 7. | Financial Literacy: A Review of Literature
<i>Mr. Nikunj Thakkar, Dr. Ankita Kathiriya</i> | 53 – 61 |
| 8. | A Comparative Study on Non Performing Assets of Public and Private Sector Banks in India
<i>Modhwadiya Santok Noghan</i> | 62 – 71 |
| 9. | Relevance of FDI Theories For Indian Outward FDI
<i>Ravinder</i> | 72 – 78 |
| 10. | To Study the Role of Banking Technology Towards Financial Inclusion in Selected Villages of Ahmedabad
<i>Nazneen Shaikh, Dr. N.D. Shah</i> | 79 – 89 |

SECTION 2: RECENT TRENDS AND PRACTICES IN MARKETING

- | | | |
|-----|--|---------|
| 11. | A Statistical Analysis On Consumer's Perception towards Online Shopping
<i>Fahmeeda Shaikh</i> | 90 – 97 |
|-----|--|---------|

See discussions, stats, and author profiles for this publication at: <https://www.researchgate.net/publication/346658530>

SMART HOME SYSTEM USING ARDUINO

Conference Paper · January 2020

CITATIONS
0

READS
3,139

3 authors:



Urvashi Parmar

Gujarat Arts and Science College, Ahmedabad, Gujarat, INDIA. (Government Colle...

4 PUBLICATIONS 5 CITATIONS

SEE PROFILE



Fatema Rajkotwala

Gujarat Arts and Science College, Ahmedabad, Gujarat, INDIA. (Government Colle...

4 PUBLICATIONS 5 CITATIONS

SEE PROFILE



Samir G Pandya

Gujarat Arts and Science College, Ahmedabad, Gujarat, INDIA. (Government Colle...

27 PUBLICATIONS 62 CITATIONS

SEE PROFILE

12th National



Science

Symposium

2020



January 19, 2020

Sponsored by



on Recent Trends in Science and Technology

Organized by **CHRIST COLLEGE, RAJKOT**

12th National Science Symposium on Recent Trends in Science and Technology (January 19, 2020)
Organized by Christ College, Rajkot & Sponsored by GUJCOST & GSBTM, Gandhinagar

First Published: 2020

Copyright © Christ College, Rajkot, Gujarat, India

Proceedings of 12th National Science Symposium on Recent Trends in Science and
Technology

ISBN: 978-81-929521-5-4

No part of this book may be reproduced or transmitted in any form by any means electronic or mechanic or mechanical, including photocopy, recording, or any other information storage and retrieval system, without permission in writing from the copy owners.

DISCLAIMER

The authors are solely responsible for the contents of the papers compiled in this volume.

The publishers or editors do not take any responsibility for the same in any manner.

Errors if any are purely unintentional and readers are requested to communicate such errors to the editors or publishers to avoid discrepancies in future.

Typeset by:

Christ College, Rajkot

Christ Campus, Vidya Niketan,

Saurashtra University P.O., Rajkot 360005 (Gujarat)

Printed in India:

Christ Publications

Christ Campus, Vidya Niketan,

Saurashtra University P.O., Rajkot 360005 (Gujarat)

SMART HOME SYSTEM USING ARDUINO**U. Parmar^{1#}, F. Rajkotwala^{1#}, S. Pandya^{1*}**¹*P.G. Department of Electronics, Gujarat Arts and Science College, Ahmedabad-380014, Gujarat, India***sp16574@gmail.com**#These authors are considered as Joint first authors***ABSTRACT**

The last decade has seen fast improvement in the field of automation. The main idea here is to build a smart home device which can be used to control the home appliances such as lights, fans, air conditioners, room heaters, television, refrigerator, dish washer, etc. via Bluetooth. We have used Bluetooth and Android smart phone to develop a Smart Home. This technique is useful for elderly and physically challenged people. Thus their difficulty to handle the devices physically reaching near the switch board and control the switches can be supported by the present home automation system which has a remote module that controls the appliances. The remote control operation is achieved by a Smart Android OS Phone. We have presented the automated approach of controlling the home appliances in a household that could ease the tasks of using the traditional method of the switch. We have also added automatic street light control system in our Smart Home. This system's motive is to design and implement user friendly, reliable, compact, simple and low cost android based smart home system.

Keyword: Arduino, Smart home, Android smart phone, LDR, Bluetooth

1. INTRODUCTION

Today most of the people uses smartphone and are interested in controlling everything through smart phone. The concept of Smart Home reduces the manpower at home. Smart Home includes a degree of automatic control to certain electrical and electronics systems. The automation process is completely controlled by bluetooth and smart phone. A smart home device can be used to control the home appliances such as lights, fans, air conditioners, room heaters, television, refrigerator, dish washer, etc. via Bluetooth. It discusses a system that makes our home more cost effective, user friendly, reliable, simple and reduces wiring cost.

2. METHODOLOGY

The main components in this system are Arduino Uno, Bluetooth module, Power supply, Relay module and Android application in the smart phone. Figure 1 and 2 respectively shows block diagram and circuit diagram of Smart Home System using Arduino. Arduino is the heart of this system. "Bluetooth controller" application is to be opened in smart phone. And then turn 'ON' the Bluetooth of that smart phone.



Figure 1. Block Diagram

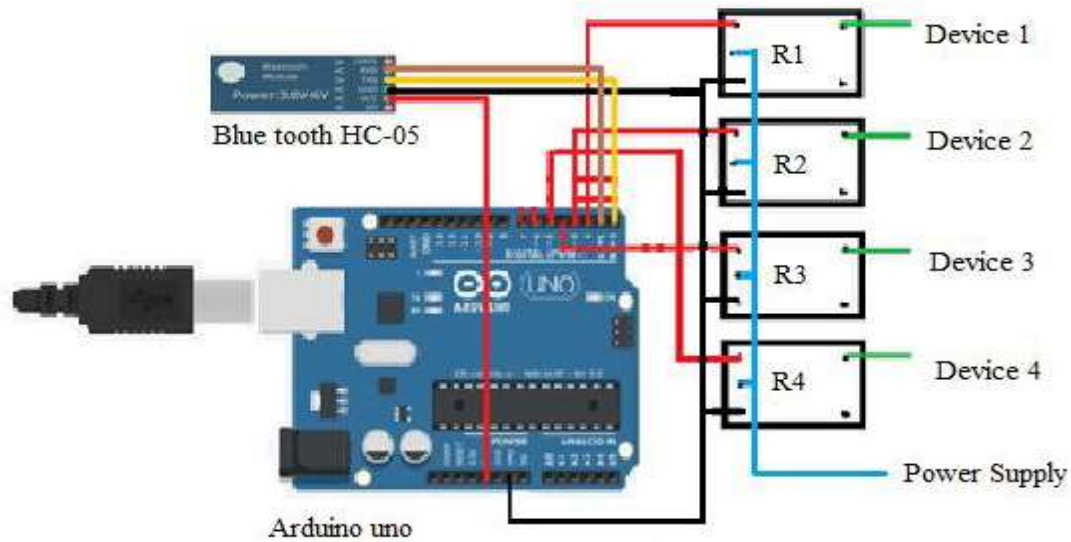
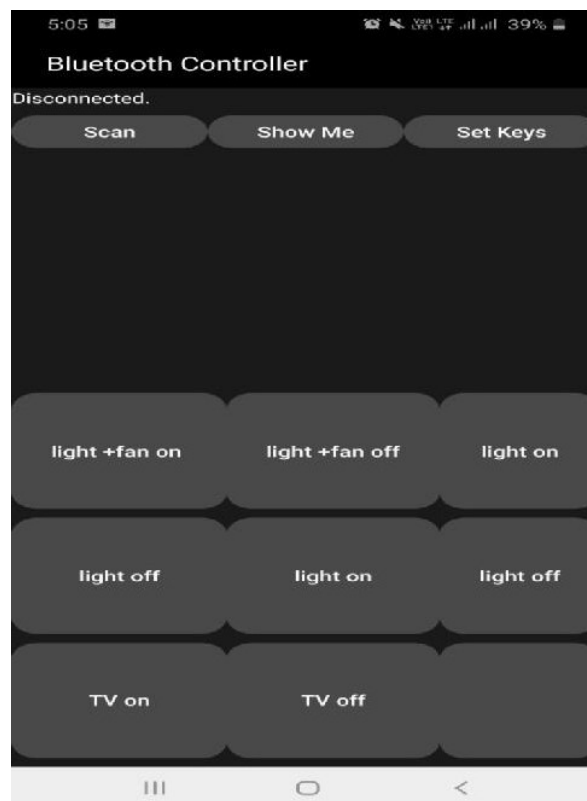

Figure 2. Circuit Diagram

After that, pair that android smart phone with Bluetooth HC-05 module. After pairing set up different keys for different appliances in the application. The image shown in figure 3 represents the keys in the application and figure 4 represents the setup of the keys in the application.

After setting up the keys in the application we can turn 'ON' or 'OFF' appliances like lights, fans, air conditioners, room heaters, television, refrigerator, dish washer, etc. We can turn 'ON' or 'OFF' appliances of a particular room while being present in another room.

For example, if "TV ON" key is pressed in the application, then the TV turns on. In the same way we can control variety of appliances.



An Applications of Statistical Models in Water Management Studies

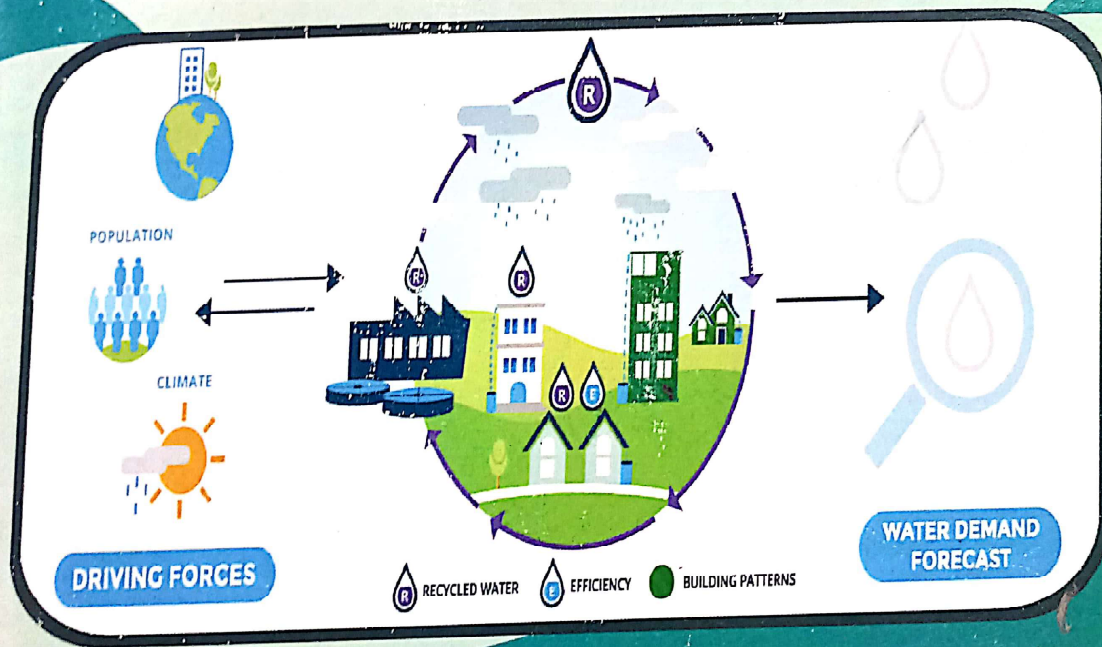

Fahmeeda F. Shaikh



DOTCOM PUBLICATIONS[®]



"Fahmeeda F. Shaikh (Ph.D scholar, M.Phil, M.Sc (Statistics, Gold Medallist)) is GPSC appointed assistant professor (GES-Class II) in dept of Statistics at Gujarat arts and science college, Ahmedabad, Gujarat. Prior to this, she was working as an assistant professor in an MBA dept. at Shri Jairambhai Patel Institute of Business Management and Computer studies (formely known as NICM). She has teaching experience of more than 12 years. She has written 5 books, published 10 articles in National and International journals, written 7 articles in edited International books and has presented more than 20 papers in National and International conferences. She topped the Gujarat University in M.Sc and was awarded six gold medals by the ex governor of Gujarat Shri Naval kishore Sharmaji in the convocation held in the year 2008. Her area of interest are Bayesian analysis, Regression and Multivariate analysis, Operations Research, Hypothesis testing, Record values, and R programming."



DOTCOM PUBLICATIONS®

(Educational Publishers)

P.B. No.-9049

Maninagar (E), AHMEDABAD-380 008

e-mail : dotcombooks@yahoo.co.in

visit us at [http : //www.dotcombooks4u.com](http://www.dotcombooks4u.com)

To get updates and share ideas, connect with us on  facebook

Group Name : Dotcom Publications



9 789387 861206

An Applications of Statistical Models in Water Management Studies

Prof. Fahmeeda F. Shaikh

Ph. D Scholar, M. Phil, M. Sc (Statistics, Gold Medallist)
Department of Statistics (GES-II)
Gujarat Arts and Science College,
Ahmedabad, Gujarat.



DOTCOM PUBLICATIONS®

(Educational Publishers)

P.B.No.-9049

Maninagar, (E) AHMEDABAD 380 008

e-mail : dotcombooks@yahoo.co.in

visit us at [http : // www.dotcombooks4u.com](http://www.dotcombooks4u.com).



The Publisher is not responsible for any omission or error though every care has been taken while preparing, printing, composing and proof reading of the Book. As all the Composing, Printing, Publishing and Proof Reading etc., are done by Humans, any and chances of Human Error could not be denied.

ISBN-9789387861190

₹ 160.60

An Applications of Statistical Models in
Water Management Studies

New Edition: 2020-21

© Reserved with the publishers only.

All rights reserved by Dotcom Publication. No part of this book is to be reproduced or transmitted in any form, Electronic, Mechanical, Photography or nay information stored in a retrieved system without prior permission in writing from Dotcom Publications, nor be otherwise circulated in any form of binding or cover other than that in which it is published without a similar condition being imposed on the subsequent purchaser.

This book is meant for education and learning purposes. The author(s) of the book has/have taken all reasonable care to ensue that the contents of the book do not violate any existing copyright or other intellectual rights of any person in any manner whatsoever. In the event the author(s) has/have been unable to track any source and if any copyright has been inadvertently infringed, please notify the publisher in writing for corrective action.

OPERATIONS RESEARCH

Fahmeeda Shaikh

Techniques for Management



About the Author

Fahmeeda F. Shaikh (Ph.D. scholar, M. Phil, M.Sc. (Statistics, Gold Medalist)) is GPSC appointed assistant professor (GES-Class II) in dept of Statistics at Gujarat Arts and Science college, Ahmedabad, Gujarat. Prior to this, she was working as an assistant professor in an MBA dept. at Shri Jairam Bhai Patel Institute of Business Management and Computer studies (formerly known as NICM). She has teaching experience of more than 12 years. She has written 5 books, published 15 articles in National and International journals, written 10 articles in edited International books and has presented more than 20 papers in National and International conferences. She topped the Gujarat University in M.Sc. and was awarded six gold medals by the ex-governor of Gujarat Shri Naval Kishore Sharma in the convocation held in the year 2008. She was also awarded with "Distinguished Academician & Researcher award in Higher Education (Statistics)" by Narain College and Global Research Foundation in the conference on " Role of Multidisciplinary studies in Environment held protection" held at Narain College, Shikohabad, Uttar Pradesh. Her area of interest are Bayesian analysis, Regression and Multivariate analysis, Operations Research, Hypothesis testing, Record values, and R programming."



Published by:
Office: 252, 2nd Floor, Plot No. 8 Aggarwal Plaza,
LSC 1, Mixed Housing Complex, Mayur Vihar,
Phase-3, New Delhi-110096, India
Phone: 011-22626549, 8368091241
Email: submission@kaavpublications.org
Website: www.kaav.org ; www.kaavpublications.org

ISBN: 978-93-88996-42-6

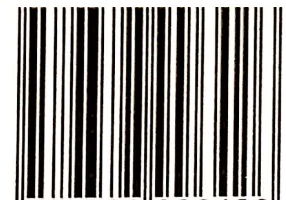

9 789388 996426 >

Price: INR 425/- US\$ 70

OPERATIONS RESEARCH TECHNIQUES FOR MANAGEMENT

FAHMEEDA SHAIKH



KAAV
PUBLICATIONS

MAYUR VIHAR PHASE 3, DELHI- 110096



Published By:

KAHV PUBLICATIONS,

2nd Floor, Aggarwal Plaza, LSC- 1,

Mixed Housing Complex, Mayur Vihar Phase 3, DELHI- 110096

Email Id.: kaavpublications@gmail.com, submission@kaavpublications.org

© Author:- Fahmeeda Shaikh

Typesetting by: Ms. Sarika

Printed By: Amit Printers, Noida

KAHV ID: KAAV/BP/A-230-20

First Edition: 2020

Price: INR 425/- US\$ 70

ISBN: 978-93-88996-42-6

KAHV PUBLICATIONS (All Rights Reserved)

Responsibility for the facts stated, opinions expressed, conclusions reached and plagiarism, if any, in this title is entirely that of the author(s) & contributor(s). The author, editor and publisher bear no responsibility for them whatsoever. All rights strictly reserved. No part of this book may be reproduced in any manner without written permission. For Binding mistakes, misprint or for missing pages etc the publisher's liability is limited.



(Estd. 1956)

NARAIN COLLEGE
SHIKOHABAD, DISTT. FIROZABAD (UP) - 283135
ACCREDITED B+ BY NAAC

International Conference *on*

Role of Multidisciplinary Studies in Environment Protection

(IC-RMSEP-2020)

Science



Technology

Agriculture



Management



Global Research
Foundation, Delhi



Souvenir

23rd Feb, 2020

*(Science II Technology II Management II
Humanities II Agriculture II Medi-Science)*



(Estd 1956)

Narain College



President

Shri. S. K. Tandon
President, N.C.S



Chief Patron

Dr. L. C. Mehra
Manager, N.C.S



Co-Chief Patron

Dr. V. K. Chaturvedi
Secretary, N.C.S



Patron

Dr. Pratap Singh
Principal, N.C.S



Chief Organizing Convener

Dr. P. K. Saraswat
Asso. Pro. & Head,
Deptt. of Physics, N.C.S.



Co-Convener

Dr. Kuldeep Saxena
Asso. Prof. & Head,
Eng. Deptt.



Co-Convener

Dr. R. K. Tripathi
Asso. Prof. & Head,
AG. Chem. Deptt.

Contact:

Narain College, Shikohabad, Uttar Pradesh- 283135, India

Mob: +91-7078390321, 9412287070

Website: www.naraincollege.ac.in | E-mail: naraincollegeconf@gmail.com



F.S. AYURVEDIC MEDICAL COLLEGE & HOSPITAL
F.S. COLLEGE OF NURSING | F.S. COLLEGE OF PHARMACY
F.S. COLLEGE OF Education | S.R.D. COLLEGE OF Education
(Ussaini Fzd)

Admission Open

BAMS | GNM | ANM | D.Pharma
B.Sc. Nursing | D. Optometry
D. Physiotherapy | D.El.Ed. | B.Ed. | M.Ed
B.A. | B.Sc. | M.Sc. | B.Com. | M.Com

For More Details Contact
9720205727 | 9675111147 | 9917286606

Hostel Facility Available | A. F. Enabling Campus | 100% Scholarship



Dr. Dilip Yadav (M.D.)
Ragging Free Campus

Add : NH-2, Near Balaji Mandir, Shikohabad, Distt. Firozabad - 283203



Published By:

Office: 203, 2nd Floor, Plot No. 7, Aggarwal Plaza,
LSC 1, Mixed Housing Complex, Mayur Vihar,
Phase-3, New Delhi-110096, India

Phone: 011-22626549, 8368091241

Email: submission@kaavpublications.org

Website: www.kaav.org ; www.kaavpublications.org

ISBN: 978-93-88996-23-5

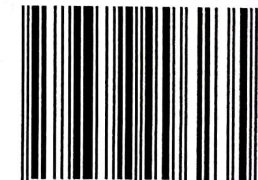

9 789388 996235 >

Price: INR 350/- US\$ 20



Narain College
Shikohabad

**NARAIN COLLEGE, SHIKOHABAD, UTTAR PRADESH
283135**

**1st INTERNATIONAL CONFERENCE
ON
IC-RMSEP-2020**

**ROLE OF MULTIDISCIPLINARY
STUDIES IN ENVIRONMENT PROTECTION
(Science II Technology II Management II
Humanities II Agriculture II Medi-Science)**

23 February, 2020 (Sunday)

President
Shri. S. K. Tandon

Chief Patron
Dr. L. C. Mehra

Co- Chief Patron
Shri. V. K. Chaturvedi

Patron
Dr. Pratap Singh

Chief Organizing Convener
Dr. P. K. Saraswat

Co-Convener
Dr. Kuldeep Saxena
Dr. R. K. Tripathi

GRF Conference Convenor
Dr Kirti Agarwal



1st International Conference 2020

First Impression: February, 2020
Copyright, Narain College, Shikohabad, Uttar Pradesh 283135

ISBN: 978-93-88996-23-5

Disclaimer

No part of this publication may be reproduced or transmitted in any form by any means, electronic or mechanical, including photocopy, recording or any Information storage and retrieval system, without permission in written form from the copyright owners.

The authors are solely responsible for the facts stated, opinions expressed, conclusions reached and plagiarism, if any, in the title is entirely that of the contributors compiled in this volume. The publishers or college administration are not responsible for the same in any manner. Errors, if any, are purely unintentional and readers are requested to communicate such errors to the editors or publishers to avoid discrepancies in future.



Published by:

KAAV PUBLICATIONS

203, 2nd Floor, Plot No- 7, Aggarwal Plaza, LSC- 1,

Mixed Housing Complex, Mayur Vihar Phase 3, DELHI- 110096

Office - 011-22626549, M - 8368091241, 7683095844

Email Id.: kaavpublications@gmail.com, submission@kaavpublications.org

Website: www.kaavpublications.org; www.kaav.org;

www.globalconference.info

Printed by: Amit Printers, Noida



LIST OF CONTRIBUTORS

Sr. No.	Title	Page No.
1.	THE EFFECTS OF PSYCHOLOGICAL GENDER AND FAMILY SUPPORT IN TEAM & INDIVIDUAL SPORTS PERFORMANCE <i>Khanna N. B., Shungloo R.</i>	1
2.	AN ANALYSIS OF WORK RELATED STRESS FACTORS IN GIDC OF AHMEDABAD <i>Dr. Bhavik U. Swadia</i>	1
3.	BAYESIAN ESTIMATION AND PREDICTION FOR EXPONENTIATED LOGISTIC DISTRIBUTION BASED ON UPPER RECORDS <i>Falmeeda F. Shaikh</i>	2
4.	GREEN MARKETING: A CONCEPTUAL SKETCH <i>Dr. Mintu Gogoi</i>	2
5.	A COMPREHENSIVE REVIEW OF CUSTOMER RELATIONSHIP MANAGEMENT <i>Dr. Sajjan Choudhuri</i>	3
6.	AN ANALYTICAL STUDY ON ENTREPRENEURSHIP DEVELOPMENT PROGRAMMES IN ASSAM <i>Dr. Sumeet Gupta</i>	3
7.	EFFICIENT TRAFFIC MANAGEMENT IN MULTITENANT CLOUD ENVIRONMENT <i>Amith Shekhar C, Dr. Sharvani. G S</i>	4
8.	A CONCEPTUAL ANALYSIS OF MARKET STRATEGIES OF MNCs IN INDIA: WITH REFERENCE TO FMCG SECTOR <i>Dr. Arti Singh</i>	4
9.	THE EFFECT OF INTERNATIONAL TRADE OVER THE ECONOMIC GROWTH IN INDIA <i>Dr. Vaseemuddin</i>	5
10.	X-RAY CHARACTERIZATION AND PIEZO/PYRO ELECTRIC PROPERTIES OF LEAD LANTHANUM ZIRCONATE TITANATE (PLZT) CERAMICS PREPARED BY SOL - GEL DERIVED NANO POWDERS <i>Dr. Anshu Sharma</i>	5
11.	AWARENESS AND USE OF E-RESOURCES BY THE RESEARCH SCHOLARS IN ALAGAPPA UNIVERSITY: A CASE STUDY <i>Dr. V. Velvizhi</i>	6
12.	A DECENTRALIZED ADAPTIVE MEDIUM ACCESS CONTROL FOR V2I VANET <i>Neelambike S, Chandrika J</i>	6



Women in Higher Education

Context, Challenges and Courage

Preeti Oza
Gurudutta Japee

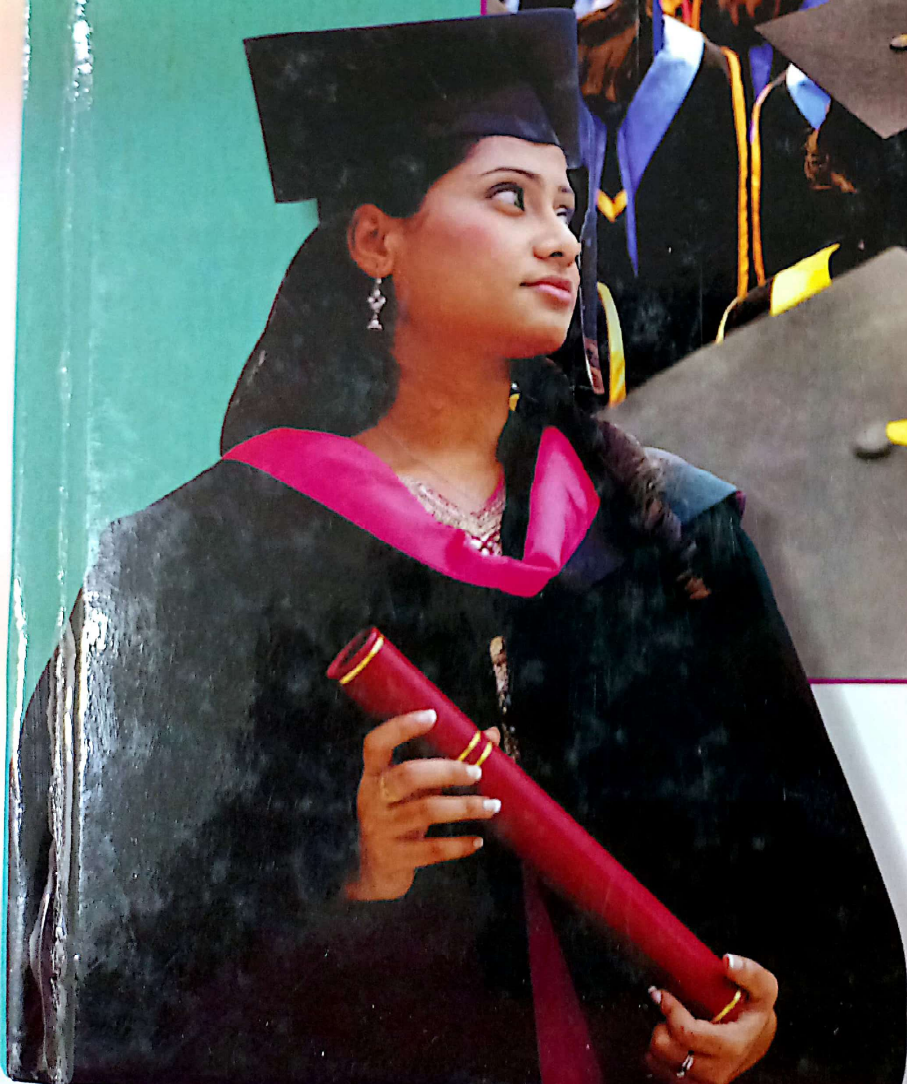
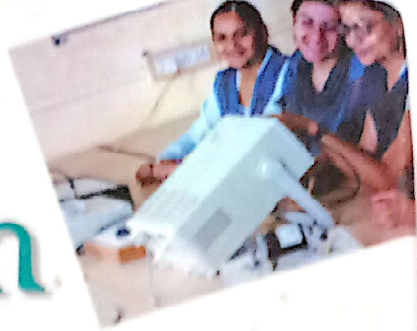

Women in Higher Education: Context, Challenges and Courage

Dr. Preeti Oza
Dr. Gurudutta P. Japee



Book Enclave
Jaipur India

Published by

Book Enclave

F-11, S.S. Tower,

Dhamani Street, Chaura Rasta,

Jaipur-302003, India

Ph: 0141-2311900, 9414443132

e-mail : bookenclave@gmail.com

Web: www.bookenclave.com

First Published in India, 2020

© Editors

ISBN : 978-81-8152-518-5

Price : Rs. 1150

Typesetting by

Vikram Kumar Sharma, Jaipur

Print and bound in India by Trident Enterprises, Noida



Contents

Preface	v
1. Higher Education and Women in India —Dr. Gurudutta P Japee	1
2. Role of Women in the Development of Indian Higher Education and Making of a Nation —Dr. Preeti Oza	15
3. Historical Role of Women in Higher Education —Dr. Satyajeet Deshpande	22
4. Development of Ambition-Women in Higher Education —Dr. Arundhati P. Dasani	30
5. Women in Higher Education-Global and Local —Prof. Nishit Parikh	33
6. Higher Education and Recognition of Women in India —Dr. Rupal S. Patel	40
7. The Positioning of Women in Higher Education in India —Prof. Gargi Gohel	48
8. Gender Equality as a Challenge for Higher Education in India —Fahmeeda. F. Shaikh	54

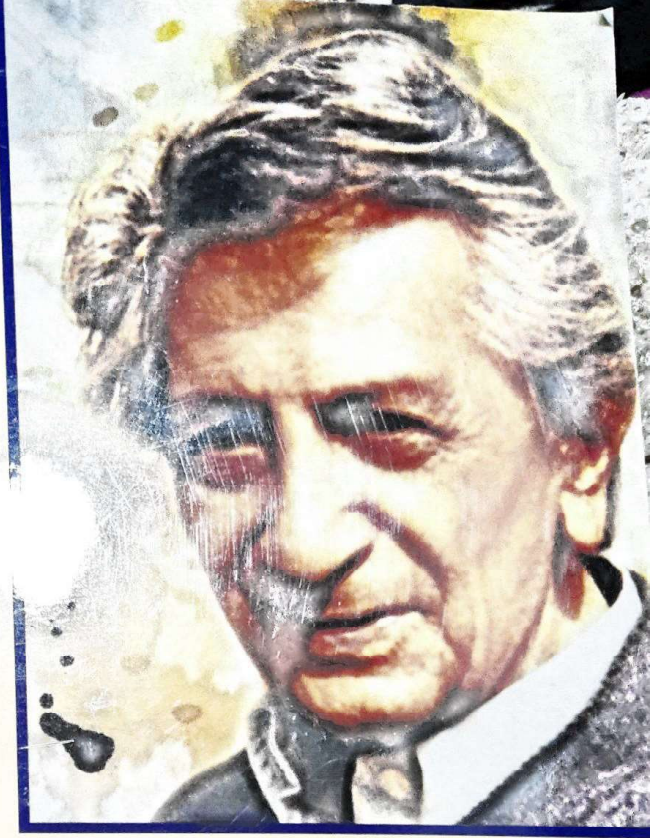

नयी कहानी के परिप्रेक्ष्य में भीष्म साहनी की कहानियों का अध्ययन

डॉ. भारती जी. ओझा

नयी कहानी के परिप्रेक्ष्य में भीष्म साहनी की कहानियों का अध्ययन

डॉ. भारती जी. ओझा

एसोसिएट प्रोफेसर,

गुजरात आर्ट्स एन्ड सायन्स कॉलेज,

एलिसब्रिज, अहमदाबाद-३८०००६

पार्श्व पब्लिकेशन : अहमदाबाद

प्रकरण	प्रकरण शीर्षक	पृष्ठ संख्या
❖	विषयचयन	A to B
❖	प्रबन्ध परिचय	C to D
❖	कृतज्ञता ज्ञापन	E
1	भीष्म साहनी :	01
1,1	व्यक्तित्व ।	
1,2	कृतित्व ।	
1,3	भीष्मजी के साहित्य का सामान्य परिचय ।	
2	नयी कहानी आंदोलन पूर्व की हिन्दी कहानी ।	38
3	नयी कहानी :	45
3,1	नयी कहानी का प्रारंभ ।	
3,2	नयी कहानी और पूर्ववर्ती कहानी में अंतर ।	
3,3	नयी कहानी आंदोलन की विशेषताएँ ।	
3,4	नये कहानीकार ।	
3,5	नयी कहानी की उपलब्धियाँ और सीमाएँ ।	
3,6	नयी कहानी के दौर में प्रकाशित भीष्म साहनी- के कहानीसंग्रह ।	
4	भीष्म साहनीकी कहानियों में नयी कहानी की विशेषताएँ:	84
4,1	कथ्यगत विशेषताएँ :	
4,1-1	: अनुभव की व्यापकता और यथार्थता ।	
4,1-2	: निम्न वर्ग का सशक्त चित्रण ।	
4,1-3	: विभाजन की पीड़ा ।	
4,1-4	: टूटते पारिवारिक रिश्ते और दो पीढ़ियों में अंतर ।	
4,1-5	: स्त्री-पुरुष संबंध ।	
4,1-6	: पाश्चात्य संस्कृति के प्रति मोह ।	
4,1-7	: पात्रों का मनोविश्व ।	
4,1-8	: व्यंग्यात्मकता ।	

4,1-9 : स्त्री संवेदना ।

4,2 शिल्पगत विशेषताएँ :

4,2-1 : भाषा ।

4,2-2 : शैली ।

5 नये कहानीकार के संदर्भ में भीष्म साहनी :-

186

साम्य-वैषम्य ।

6 उपसंहार ।

219

7 संदर्भसूचि।

225

परिशिष्ट-1 : आधारग्रंथ सूची

परिशिष्ट-2 :क) सहायक ग्रंथ सूची : कहानीसंग्रह
ख) सहायक संदर्भ ग्रंथ सूची

परिशिष्ट-3 : पत्रिकाएँ
कोश



डॉ. भारती ओझा (GES II)

(एसोसिएट प्रोफेसर)

- शिक्षा** : बी.एड., एम.ए., एम.फिल., पीएच.डी., डीप्लोमा इन टेम्पल मेनेजमेन्ट, ग्राफोलोजी (बेजिक प्रेक्टीशनर)।
- कार्य** : गुजरात विश्वविद्यालय की कॉलेजों में १९९८ से स्नातक और २००४ से अनुस्नातक कक्षाओं में अध्यापन। राष्ट्रीय एवं आंतर्राष्ट्रीय संगोष्ठियों में हिस्सा एवं प्रपत्र पठन, ISSN जर्नल एवं ISBN पुस्तकों में लेख एवं अनुवाद प्रकाशित।
- सह-संपादक** : स्त्री लेखन : सृजन और संदर्भ।
- लेखन** : कहानी एवं कविता।
- विशेष** : CPIFT, गांधीनगर, गुजरात में तीन वर्ष विजिटिंग प्रोफेसर।

ISBN : 978-93-84748-17-3



₹ 625-00



पार्श्व पब्लिकेशन : अहमदाबाद



ISSN 2454-8596
www.MyVedant.com

An International Multidisciplinary Research E-Journal

Understanding the Modern Pandemics through AIDS Poetry: A Comparative Study

Jaykumar Harish Buddhdev

Assistant Professor

Gujarat Arts and Science College, Ahmedabad



Abstract

Looking back at the AIDS Crisis of the 1980s and 1990s in the United States, through the poems “What the Intern Saw” by Phillis Levin and “How to Watch Your Brother Die” by Michael Lassell, this paper presents an analogy between the past and present pandemics unleashed on modern life. Through the prism of these AIDS poems an attempt is made to illustrate the American history of the AIDS crisis. Akin to the present fears, extreme anxiety and xenophobia engendered by COVID-19, the AIDS pandemic too exploded with similar yet contrasting instances almost four decades ago. Through these poems an attempt is made to connect the condition of the urban gay male community along with the perspectives of the general population. Furthermore, the aim here is to disengage and strip off the social meanings and metaphors that accompanied AIDS so as to look at it as it ought to be seen. The ongoing COVID-19 pandemic is also compared and contrasted with the AIDS crisis so as to frame a possible narrative for a world after this present health-care emergency.

Keywords: COVID-19, AIDS, HIV, AIDS Literature, AIDS Poetry, American literature, gay identity, homophobia

The COVID-19 (Coronavirus disease) pandemic has already altered the way we live our lives. The extensive lockdown, while necessary, has driven home the severity of this global health crisis. There have been a number of pandemics in the past, pandemics which have altered the course of human history. With the present paper, an attempt is made to study AIDS - Acquired Immune Deficiency Syndrome, one of the most horrific modern pandemics, through the medium of the chosen AIDS poems “What the Intern Saw” by Phillis Levin and “How to Watch Your Brother Die” by Michael Lassell. The paper will briefly look into the history of AIDS, its early social meanings which have yet to leave the popular consciousness in the United States of America. The paper will compare the homophobia and fears engendered by the AIDS crisis in the 1980s and 1990s to the present xenophobia and anxiety born out of the present-day crisis. The urban gay male community will be the locus of this paper and it will also present the disengagement and fears of the ‘general population’ vis-à-vis AIDS and homosexuality. The paper will also briefly dwell on the origin of AIDS with reference to Susan Sontag’s 1989 text *AIDS and its Metaphors*.



The chosen poems, “What the Intern Saw” by Phillis Levin and “How to Watch Your Brother Die” by Michael Lassell, present perspectives which although dealing with the consequences of AIDS, do not directly include the Person with AIDS (PWA) as the major voices as a part of their respective narratives. While the former deals with the effect of AIDS, particularly its physical manifestations, on the mind of a medical intern, the latter presents a heterosexual man, an individual from the so-called ‘general population’ suddenly put in the midst of his gay brother dying with AIDS in a hospital (Stevenson 249). The narrators of both these poems are fascinatingly presented as almost passive observers, especially in case of Lassell’s poem, unable to make sense of the suffering of the young homosexual PWAs. These poems also reveal the stigmatized status of the male homosexual community in the United States of America since the early 1980s with the advent of the AIDS epidemic (Plummer 28, Shilts 138, Treichler 31). Levin’s poem was published in her 1988 volume *Temples and Fields*, while Lassell’s poem was published in 1985 in the volume *Poems for Lost and Un-Lost Boys*. Both the poems were also anthologised in the 1989 collection *Poets for Life: Seventy-Six Poets Respond to AIDS* edited by Michael Klein.

Phillis Levin (b. 1954), the American poet, editor, translator and academician, is the recipient of the Ingram Merrill Award (1986), the Amy Lowell Poetry Travelling Scholarship (1999-2000), the Guggenheim Fellowship (2003), and the National Endowment for the Arts Fellowship (2007). She is the author of five poetry collections: *Temples and Fields* (1988, winner of the Poetry Society of America’s Norma Farber First Book Award), *The Afterimage* (1995), *Mercury* (2001), *May Day* (2008), and *Mr. Memory & Poems* (2016). She is also the editor of *The Penguin Book of Sonnet: 500 Years of a Classical Tradition in English* (2001) (Phillis Levin). Born in 1947, Michael Lassell is an American poet, essayist, and editor best known for his 1985 volume *Poems for Lost and Un-Lost Boys*. He has written expansively on the theatre and GLBT studies. His other major works include *Decade Dance* (1990), *The Hard Way* (1994) *The Name of Love: Classic Gay Love Poems* (ed. 1995), and others. He is best known for the chosen poem of this paper “How to Watch Your Brother Die”. He was awarded the Lambda Literary Award for Poetry in 1990 for the volume *Decade Dance*. The chosen poems, identified as ‘AIDS poems’, are part of the continuum of AIDS



literature which emerged as a response to the AIDS crisis. The function of these AIDS poem was to:

provide a historical record, commemorate the dead, console readers directly affected by HIV, encourage empathy from those not yet touched, rage against public mismanagement of the epidemic, and forge alternative narratives. (Landau 194)

Levin and Lassell along with other poets like Paul Monette, Thom Gunn, Mark Doty, Marie Howe, Essex Hemphill, and Melvin Dixon have contributed immensely to the subgenre of AIDS poetry which deal with the consequences of the AIDS (Pastore 254-55). The other literary genres dealing with AIDS include plays, short stories and novels, along with the performative and visual art forms like cinema, painting, dance and so on.

In order to read these poems as a response to the AIDS pandemic, one primarily needs to understand the meaning of the term 'pandemic'. A pandemic, according to the Merriam-Webster dictionary, is "an outbreak of a disease that occurs over a wide geographic area and affects an exceptionally high proportion of the population" (*Pandemic*). The World Health Organization (WHO) defines a pandemic as a "worldwide spread of a new disease" (*What is a Pandemic?*). The most known modern pandemics are the HIV/AIDS pandemic, the Flu pandemic of 1968, the Asian Flu (1956-58), and the Spanish Flu of 1918-19 (Miller & Miller).

AIDS, one of the most recent modern pandemics, by itself, is not the name of an illness. According to Susan Sontag, AIDS is the "name of a medical condition, whose consequences are a spectrum of illnesses" (102). One is said to have this 'medical condition' on the basis of the presence of a "roster of symptoms" which signifies that the patient has AIDS (106). It is a permanent condition which occurs in three stages. The first is a "long latency period between infection and the onset of 'tell-tale' symptoms" known as human immunodeficiency virus (HIV) as observed by Sontag (107). An individual is said to be 'seropositive' when he/she tests positive for HIV antibodies. This leads to the second stage called ARC - AIDS-related complex - which includes "symptoms of immunological deficit such as fever, weight loss, fungal infections, and swollen lymph glands" (106). In the final



stage, which is AIDS, the patient is infected by diseases like pneumocystis carinii pneumonia (PCP), Kaposi's sarcoma (KS), and others (Gilman 89). It is necessary to note that while Sontag certainly discusses the psychological and social implications of this condition, she merely alludes to its then most prominent risk groups – the intravenous drug users, the homosexual men, people of colour and even the haemophiliacs. Her text, *AIDS and its Metaphors*, does not truly acknowledge the history of this medical condition and does not shed any light on the origin of the term AIDS or its predecessor GRID.

The condition, known as AIDS today, was first discovered in 1979 in the United States, in a “group of patients”, all young gay men suffering from “a rare form of cancer Kaposi's sarcoma” (KS) which strikingly manifested as “bluish or purplish-brown lesions on the skin” (Gilman 89). “Twenty-six such cases” were reported by June 1981 along with “five cases of pneumocystis carinii pneumonia (PCP),” an illness caused by a certain parasite which “manifests itself only in individuals with depressed immune systems” (89). The Centers for Disease Control (CDC) reported these findings in their *Morbidity and Mortality Weekly Report* (MMWR) in the same month. Furthermore, this CDC report stated that the patients were all young ‘homosexual’ men living in large urban areas like New York, Miami, Los Angeles, and San Francisco. These reports gave credence to some of the earliest public discourses which associated this health crisis with the sexual identity of the patients thereby leading to the proliferation of such discourse in mainstream media like *The New York Times* (89). Also, this condition was thus provisionally named GRID - Gay-related Immunodeficiency. However, when other minorities and marginal groups like haemophiliacs, heroin addicts and Haitians (and other people of colour) and then subsequently heterosexual women and men become infected, this viral condition was officially baptized as AIDS in September 1982. It was in May 1983, two years after the health crisis was first identified, when HIV was identified as “the virus that causes” it (Shafer). While the AIDS pandemic is mired with political inaction and medical negligence as during its early years, in the United States, it was seen as “a disease of the urban poor (and homosexuals)” (Sontag 160). Moreover, AIDS was considered to be the “plague of cities which have traditionally been seen as the harbours of disease and degeneracy” (Gilman 103). Presently, with COVID-19, a different yet similar rhetoric has taken shape in the popular imagination.



The origin of COVID-19, on the one hand, in the public consciousness, has its origin story more or less 'fixed'. In late 2019, someone at the now infamous "Huanan seafood market in Wuhan", China was "infected with a virus from an animal" (Readfearn). The WHO has described COVID-19 as an "infectious disease caused by a newly discovered coronavirus" (*Coronavirus*). Furthermore, the WHO has stated that

Most people infected with the COVID-19 virus will experience mild to moderate respiratory illness and recover without requiring special treatment. Older people, and those with underlying medical problems like cardiovascular disease, diabetes, chronic respiratory disease, and cancer are more likely to develop serious illness. (*Coronavirus*).

On the other hand, the on-going story of COVID-19 is already coloured by conspiracies which either consider it to be manmade in a laboratory and 'accidentally' leaked into the general population, or, it believed to be biological weaponry deliberately set free upon the globe. These ubiquitous conspiracies and scandals have become 'viral' through the present social media. Given that this is "the first pandemic of the social media era", it is not entirely surprising that "misinformation, conspiracy theories and even racist slurs" have flooded various online forums (Elie, White). A major world leader had termed COVID-19 as "Chinese Virus", one of his delegates termed it as "Kung Flu", and another called it the "Wuhan Virus" (Rogers et al, White). Akin to the HIV/AIDS pandemic, there is a sentiment of fear and anger accompanied by anxiety of mortality as more than two lakh and thirty-eight thousand lives have been lost and over three million have been infected in two hundred and fifteen countries as of this writing, as reported by the WHO (*Coronavirus*). The historiography of COVID-19 is still in the making. It is already accompanied by an element of an international whodunit with the global superpowers pointing fingers and lawsuits at the country of its origin (Rogers et al, White). However, it cannot be debated that the rhetoric of xenophobia is already born and flourishing.

There is already a body of AIDS literature with a set of functions that aimed to defy the popular homophobic (and also racist) narrative that was a part of the mainstream consciousness, as stated earlier. The earliest major literary works dealing with AIDS were the novel *Facing It* (1984) by Paul Reed and the plays *As Is* (1985) and *The Normal Heart* (1985)



by Larry Kramer (Pastore 3, 9). The first official report confirming cases of GRID/AIDS had come out in 1981. Hence, it took almost three to four years into the pandemic for the first major literary works to enter the public consciousness. It is thus probably a little early to expect literary works dealing with the COVID-19 to be in currency given that the world is still in the midst of a lockdown. However, one can learn to imagine a world in the midst and possibly after COVID-19, through an analysis of the narratives presented in the selected poems.

Phillis Levin's poem, "What the Intern Saw", is split into three sections – each dealing a visual aspect of the suffering engendered by the AIDS crisis in the perspective of the titular 'intern'. The poem functions as a third-person narrative of the intern whilst it serves an almost disinterested yet profoundly detailed description of the horrors of the reality of AIDS. It dwells on the physical suffering of those who had the 'disease' and its effects on the said medical intern. The very opening lines of the poem establish this aspect of the poem,

He saw a face swollen beyond ugliness

Of one who just a year ago

Was Adonis

Practicing routines of rapture:

(Levin 424)

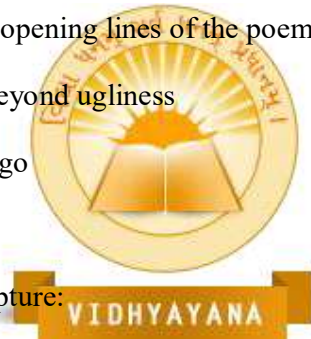

The above lines present to the readers, through the intern, an aspect typical of many AIDS poems. This opening section immediately foregrounds "the sudden, unnatural ageing and extensive disfigurement" of the PWA who, until 'a year ago', was an 'Adonis' (Stevenson 249). This juxtaposition of the boy's physical appearance within the opening lines is typical of the poem's "structure of contrasts" (249). This element of contrast is seen in the succeeding as well,

A boy who could appear

To dodge the touch of time,

Immortal or immune –



A patient in a gown,

Almost gone.

(Levin 424)

This section of the poem highlights the PWA's physical "deterioration" (Stevenson 249). This is further evidenced by its rhymes – ugliness/Adonis, immune/gown/gone – which position a certain visuality of physical beauty and its terrifying loss, and the glow of youth and its metamorphosis into a grotesque figure. Moreover, the presence and perspective of the 'intern' as the guide for the readers makes this an 'atypical' choice on the poet's part (249). A good number of literary works engaged with AIDS, often involve an insider, someone who's either a PWA himself, or is a caretaker of one, or someone who is a part of the gay or AIDS community in some manner. Here, the intern represents "an unusually distanced viewpoint", someone who is still not a doctor or health care worker; he is rather a representative of the individuals who are not intimately associated with the disease (249). This is demonstrated in the following section of the poem, wherein the poet shatters the intern's and thus also her readers view by stating,

In the beautiful school of medicine

He read about human suffering,

A long horrible drama

Until the screen of anaesthesia

And penicillin's manna.

(Levin 424)

It can be observed from the above lines, 'human suffering' was considered to be a thing of the past. In the times after radical advancements of modern medicine, that includes 'anaesthesia' and the boon which was 'penicillin', such ghastly suffering was inconceivable. The intern's idealism that informed his time at medical school is juxtaposed with "a state of fear and vulnerability" that also ages him in a "transformation parallel" to that of the PWA (Stevenson 249). He considers the hospital as

a land of the freely

Estranged from the dead, he meets

That face and fear seizes his body.

(Levin 424)

The intern, now broken away from his former idealism, is painfully transformed into a figure representing “this experience” brought about by AIDS and its accompanying suffering (Stevenson 249). In the concluding section of the poem, the poet increases her scrutiny on this enlightened figure. The intern’s daily experience of having to ‘meet’ many such ‘face(s) swollen beyond ugliness’, this cycle of having to witness such transformations and eventual deaths of the PWAs, corrodes his own innocence and youth. This routine of death makes him feel like “he must be getting older” (Levin 245). These horrors follow him even when

He shuts his eyes

And in his sleep he sees a gleaming bar,

The shore of pain.

It isn't far.

People live there.

(Levin 425)



The intern is so consumed by the pain and suffering he has witnessed that even his sleep is infected by them. The sea of pain that he encounters in his sleep is peopled by those whom he sees in the hospital. The intern is, much like the PWA seen in the opening of the poem, fully consumed by horrors of AIDS. Similar trends are already evident in the present with the COVID-19 pandemic in both the US and India (Madhavan, Wan). Thus, the trauma of both AIDS and COVID-19 is not limited to those immediately affected by it, but its effects are also witnessed in the case of the health care workers as well.

The words used to describe the PWA in “What the Intern Saw” are deceptively simple. This person with AIDS is seen as an ‘Adonis/ Practicing routines of rapture’. The word ‘rapture’ is very telling for it suggests that this young man, once untouched by time, was until



very recently entangled in the routines of intense joy. One can only speculate whether Levin is suggesting a pre-AIDS gay life. However, the selection of these words is noteworthy. Levin's words are devoid of judgement, unlike "homophobic myths" that had "organized (the) public response to AIDS" (Landau 193). The poet subtly defies the ubiquitous notions of the 1980s and early the 1990s wherein the "guardian of public morals" stated that AIDS was "God's punishment" and the "revenge of nature" on gay men (Shilts 331, Sontag 147). Levin's poem is thus "an appropriate response" to the demonizing discourses" which were commonplace at the height of the AIDS crisis (Landau 194). She does not levy any charges on the person with AIDS. This beautiful man and his 'routines of rapture' are presented as-is. He is described on the basis of his sufferings and not on the basis of his sexual identity. This 'Adonis' is now a passive, almost a tragic figure broken beyond repair. This poem thus functions as a discourse that deals with those immediately affected by AIDS, the person with it and the health care practitioner.

Michael Lassell's "How to Watch Your Die" is a much more personal and intricate poem that presents itself as "an exploration of a meeting between a heterosexual man, his dying brother, and his brother's male lover (Bona 220). Here the heterosexual man, while 'Dantesque', is presented as a baffled yet identifiable figure for the general population. He is the one that navigates the narrative of this poem which has twelve stanzas. Each stanza represents a unique experience for this heterosexual individual who is suddenly thrust in the centre of the AIDS crisis. It is interesting that Lassell has chosen to write the poem in the second person, thereby addressing not only the narrator in a confessional and personal manner but also making the reader a part of the narrative. The poem, much like Levin's work, begins with a direct focus on the physical condition of the dying individual,

When the call comes, be calm.

Say to your wife, "My brother is dying. I have to fly to California."

Try not to be too shocked that he already looks like a cadaver.

(Lassell)

These lines foreground death as the poem's central feature along with a few other issues. The narrator seems to be anticipating this call from 'California' – a known gay heaven – as he



cautions himself to 'be calm'(Shilts 15). This places the poem historically in the midst of the AIDS epidemic when such phone calls were commonplace. Through the course of the poem, Lassell's narrator and subsequently his readers are informed about the hardships faced by the PWAs and the gay community in particular. This is illustrated through the various interactions he has with other characters in the poem. This includes the lover, the wife the doctor, the border guard, and the funeral director. It is important to note that the titular brother dying of AIDS is devoid of personality as he is already likened to a corpse in the above lines. This description is not as poetic as it is suggestive of a debilitating aspect of AIDS – massive weight loss which transformed him into a 'cadaver'. Much like Levin's poem, the dying individual is described as-is in the opening lines of this work as well. The poet conflates the primary conflict of his work, AIDS, along with another conflict which is immediately revealed through the following lines,

Say to the young man sitting by your brother's side,

"I'm his brother."

Try not to be shocked when the young man says,

"I'm his lover. Thanks for coming."

(Lassell)

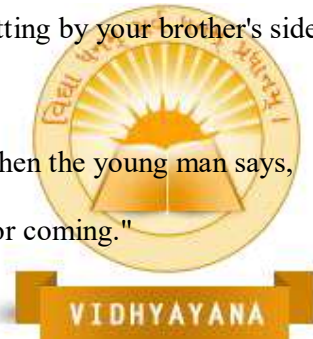

The narrator is 'shocked' that his brother had a lover. He watches "the lover's eyes as they stare into" his brother's, who staring "into space" (Lassell). The description of the deep affection displayed by the brother's lover is baffling to the narrator. He is further troubled when the lover is seen crying in the hospital cafeteria. He is unable to make sense of their relationship and sexuality. Homosexuality is a major taboo for the mainstream society and through the course of this poem, Lassell discloses that the siblings were estranged due to the dying brother's sexual identity (Shilts 15). This is revealed when the unnamed lover tells the narrator to "forgive" himself "for not wanting to know" his sibling after he came out to him. The narrator wants to makes sense of their identity when he acknowledges that he does not "know what it means to be the lover of another man". The lover replies, "It's just like a wife, only the commitment is deeper/because the odds against you are so much



greater" (Lassell). These 'odds against' them are immediately revealed when the narrator, in his genuine desire to understand their relationship, asks his wife

"How could anyone's commitment be deeper than
a husband and wife?" Hear her say,

"Please. I don't want to know the details."

(Lassell)

The wife's reaction is indicative of explicit homophobia of the general population. Her total disregard, to her husband's dying brother simply because of his homosexuality, is not a singular incident. Her reaction is not just homophobia but it is also the inescapable AIDS-phobia, which was in currency at the height of the AIDS pandemic in the 1980s and early 1990s (Román 60, Shilts 311, 353). The narrator continues to feel troubled by the actions and reactions of various people around the PWAs in the city.

The doctor is described as having a "steel face on" and being "remote" (Lassell). The narrator is unable to understand why the health care professional does not display an iota of compassion for his dying brother. All he gets from the hospital are the "necessary forms", mere formality devoid of sympathy. In order to save his brother, he drives to Mexico with the lover for "unproven drugs", which he is not allowed to carry across to the United States by the border guard. It is in the eyes of this guard the narrator sees "how much a man can hate another man" (Lassell). The guard knows these drugs are for AIDS, and thereby assumes for a gay man. The narrator is unable to grapple with the intensity of the guard's hatred, which his brother's lover states is something gay people have always dealt with (Shilts 353). AIDS was, in the mid-1980s, considered to be the disease of the outcasts and social pariahs like the gay community (Buddhdev). The exercise of trying to get untested medicines is not exclusive to the AIDS crisis, as it is being witnessed today during the present pandemic as well.

After the titular brother's death, it is the narrator who comforts the lover. It is the narrator who helps the lover in making the funeral arrangement. He encounters the funeral director who refuses to "embalm the body for fear of contamination" (Lassell). His anger at such disregard towards his brother whom he has lost to AIDS is palpable. However, this refusal to respectfully bury a person with AIDS is not exclusive to the AIDS pandemic alone.



Such instances have already been witnessed in case of COVID-19 in the US and India (Ellis-Petersen, Rosen). Lassell's poem ends with the narrator returning to his family after his brother's funeral.

"How to Watch Your Brother Die" is work "less concerned with poetry than with conveying the terrible truth" of having to witness AIDS as a first-hand experience (Stevenson 241). The poet, through his unnamed heterosexual narrator, presents a picture of the AIDS pandemic when it was "widely perceived in America as a disease primarily affecting (gay) men and, in fact, as devastating whole communities of gay men" (243). Here the Dante-like narrator navigates the world of AIDS and homosexuals so that the readers can get a glimpse of the 'odds' against them.

One can deal with the present after one has made sense of the past. By looking back at the origin of the AIDS crisis of the 1980s and 1990s in the United States and through a study of the chosen poems, "What the Intern Saw" by Phillis Levin and "How to Watch Your Brother Die" by Michael Lassell, this paper has presented an analogy between the past and present pandemics unleashed on modern life. Both poems focus on people with AIDS (PWA) and the effect of their suffering on those around them. In case of Levin's poem, the focus is on the mental health of medical intern. In case of Lassell's work, the focus is firmly on the urban gay community and also the general population. Depressed health care workers, refusal to bury the dead with dignity, fears of contamination exist today as much as they did in the past. Discrimination of those associated with the pandemic has been observed in both cases. To imagine a world after COVID-19 is the only way the world can move ahead. While no vaccine has been found for the HIV till date, there are pathbreaking medicines which have arrested the growth of its causal virus (*HIV Vaccines*). Thus, the present narrative of HIV/AIDS has been shaped by these medicines. One can possibly imagine a post-COVID-19 narrative after a vaccine or medicine has been introduced to the world. And a cooperative global race for a vaccine for COVID-19 has already begun.

Works Cited



“Amid Covid-19 Crisis, Anti-China Sentiment Highest Since 1989 Tiananmen Square Incident: Report.” *News18*, News18, 4 May 2020, www.news18.com/news/world/amid-coronavirus-crisis-anti-china-sentiment-highest-since-1989-tiananmen-square-incident-report-2605207.html.

Bona, Mary Jo. “Gay and Lesbian Writing in Post-World War II America. *A Concise Companion to Postwar American Literature and Culture*, edited by Josephine G. Hendin, Blackwell Publishing Ltd. 2004, pp. 210-237.

Buddhdev, Jaykumar H. “Institutional Silence as a Form of Homophobia in ‘AIDS Plays’ *The Normal Heart* and *As Is*.” *Sahityasetu* #ISSN:2249-2372, May 2020, www.sahityasetu.co.in/issue57/jay.html.

“Coronavirus.” *World Health Organization*, World Health Organization, www.who.int/health-topics/coronavirus#tab=tab_1.

“Coronavirus.” *World Health Organization*, World Health Organization, www.who.int/emergencies/diseases/novel-coronavirus-2019.

Elie, Paul. “(Against) Virus as Metaphor.” *The New Yorker*, Condé Nast, 20 Mar. 2020, www.newyorker.com/news/daily-comment/against-the-coronavirus-as-metaphor.

Ellis-Petersen, Hannah. “Mobs Stop Indian Doctors' Burials: 'Covid-19 Took His Life, Why Take His Dignity?'” *The Guardian*, Guardian News and Media, 29 Apr. 2020, www.theguardian.com/world/2020/apr/29/mobs-stop-indian-doctors-burials-covid-19.

Gessen, Masha. “What Lessons Does the AIDS Crisis Offer for the Coronavirus Pandemic?” *The New Yorker*, Condé Nast, 8 Apr. 2020, www.newyorker.com/news/our-columnists/what-lessons-does-the-aids-crisis-offer-for-the-coronavirus-pandemic.

Gilman, Sander L. “AIDS and Syphilis: The Iconography of Disease”. October, vol. 43, 1987, pp. 87-107. *JSTOR*, www.jstor.org/stable/3397566?seq=1



“HIV Vaccines.” *HIV.gov*, MHAFF, 24 Feb. 2020, www.hiv.gov/hiv-basics/hiv-prevention/potential-future-options/hiv-vaccines.

Klein, Michael, ed. *Poets for Life: Seventy-Six Poets Respond to AIDS*. Crown Publications, 1989.

Landau, Deborah. “How to Live. What to Do.”: The Poetics and Politics of AIDS. *American Literature*, vol. 68, no. 1, Mar., 1996, pp. 193-225. *JSTOR*, www.jstor.org/stable/2927547

Michael, Lassell. “How to Watch Your Brother Die”. *Lunanina*. LunaNina, <http://www.lunanina.com/watching.php>

Levin, Phillis. “What the Intern Saw”. *New England Review and Bread Loaf Quarterly*, vol. 9, no. 4, Summer 1987, pp. 424-425. *JSTOR*, www.jstor.org/stable/40242210

Miller, Korin, and Korin Miller. “6 Of the Worst Pandemics in History.” *Health.com*, 28 Jan. 2020, www.health.com/condition/infectious-diseases/worst-pandemics-in-history.

“Pandemic.” *Merriam-Webster*, Merriam-Webster, www.merriam-webster.com/dictionary/pandemic.

Pastore, Judith Laurence. “Introduction”. *Confronting AIDS through Literature: The Responsibilities of Representation*, edited by Judith Laurence Pastore, University of Illinois Press. 1993, pp. 1-12.

“Phillis Levin.” *Poetry Foundation*, Poetry Foundation, www.poetryfoundation.org/poets/phillis-levin.

Madhavan, Ranjani. “Doctors in the Dumps: Depression, Suicidal Thoughts up amid COVID-19 Crisis.” *The New Indian Express*, The New Indian Express, 24 Apr. 2020, www.newindianexpress.com/states/karnataka/2020/apr/24/doctors-in-the-dumps-depression-suicidal-thoughts-up-amid-covid-19-crisis-2134463.html.

Readfearn, Graham. “How Did Coronavirus Start and Where Did It Come from? Was It Really Wuhan's Animal Market?” *The Guardian*, Guardian News and Media, 28 Apr.



2020, www.theguardian.com/world/2020/apr/28/how-did-the-coronavirus-start-where-did-it-come-from-how-did-it-spread-humans-was-it-really-bats-pangolins-wuhan-animal-market.

Rogers, Katie, et al. "Trump Defends Using 'Chinese Virus' Label, Ignoring Growing Criticism." *The New York Times*, The New York Times, 18 Mar. 2020, www.nytimes.com/2020/03/18/us/politics/china-virus.html.

Román, David. *Acts of Intervention: Performance, Gay Culture, and AIDS*, Indiana University Press, 1998.

Rosen, Jody. "How Covid-19 Has Forced Us to Look at the Unthinkable." *The New York Times*, The New York Times, 29 Apr. 2020, www.nytimes.com/2020/04/29/magazine/covid-hart-island.html.

Shafer, Scott. "Could Lessons From The Early Fight Against AIDS Inform The Coronavirus Response?" *NPR*, NPR, 10 Apr. 2020, www.npr.org/sections/health-shots/2020/04/10/831045850/could-lessons-from-the-early-fight-against-aids-inform-the-coronavirus-response.

Shilts, Randy. *And the Band Played On: Politics, People, and the AIDS Epidemic*, St. Martin's Press, 2007.

Sontag, Susan. *Illness as Metaphor and AIDS and its Metaphors*, Penguin Books, 2002.

Staff. "Outbreak: 10 of the Worst Pandemics in History." *MPH Online*, www.mphonline.org/worst-pandemics-in-history/.

Stevenson, Sheryl. "'World War I All Over': Writing and Fighting the War in AIDS Poetry". *College Literature*, vol. 24, no. 1, Feb., 1997, pp. 240-262. *JSTOR*, www.jstor.org/stable/25099640

Treichler, Paula. "AIDS, Homophobia, and Biochemical Discourse: An Epidemic of Signification." *October*, vol. 43, Winter, 1987, pp. 31-70. *JSTOR*, <https://www.jstor.org/stable/3397564>



Wan, William. “The Coronavirus Pandemic Is Pushing America into a Mental Health Crisis.” *The Washington Post*, WP Company, 4 May 2020, www.washingtonpost.com/health/2020/05/04/mental-health-coronavirus/.

“What Is a Pandemic?” *World Health Organization*, World Health Organization, 12 Mar. 2020, www.who.int/csr/disease/swineflu/frequently_asked_questions/pandemic/en/.

White, Edmund. “Fear, Bigotry and Misinformation – This Reminds Me of the 1980s Aids Pandemic | Edmund White.” *The Guardian*, Guardian News and Media, 6 Apr. 2020, www.theguardian.com/commentisfree/2020/apr/06/1980s-aids-pandemic-coronavirus-gay-community-survive?fbclid=IwAR2VJScZWkfSOEICwDkNFZdLO7NrxTeFUuQuOheoLISXrVFMWXXh0iuAiT8.



Operations Research Techniques For Management



Fahmeeda F. Shaikh



DOTCOM PUBLICATIONS[®]



"Fahmeeda F. Shaikh (Ph.D scholar, M.Phil, M.Sc (Statistics, Gold Medallist)) is GPSC appointed assistant professor (GES-Class II) in dept of Statistics at Gujarat arts and science college, Ahmedabad, Gujarat. Prior to this, she was working as an assistant professor in an MBA dept. at Shri Jairambhai Patel Institute of Business Management and Computer studies (formely known as NICM). She has teaching experience of more than 12 years. She has written 5 books, published 10 articles in National and International journals, written 7 articles in edited International books and has presented more than 20 papers in National and International conferences. She topped the Gujarat University in M.Sc and was awarded six gold medals by the ex governor of Gujarat Shri Naval kishore Sharmaji in the convocation held in the year 2008. Her area of interest are Bayesian analysis, Regression and Multivariate analysis, Operations Research, Hypothesis testing, Record values, and R programming."



DOTCOM PUBLICATIONS®

(Educational Publishers)

P.B. No.-9049

Maninagar (E), AHMEDABAD-380 008

e-mail : dotcombooks@yahoo.co.in

visit us at [http : //www.dotcombooks4u.com](http://www.dotcombooks4u.com)

To get updates and share ideas, connect with us on  facebook

Group Name : Dotcom Publications



OPERATIONS RESEARCH TECHNIQUES FOR MANGEMENT

Prof. Fahmeeda F. Shaikh

Ph. D Scholar, M. Phil, M. Sc (Statistics, Gold Medallist)
Department of Statistics (GES-II)
Gujarat Arts and Science College,
Ahmedabad, Gujarat.



DOTCOM PUBLICATIONS®

(Educational Publishers)

P.B.No.-9049

Maninagar, (E) AHMEDABAD 380 008

e-mail : dotcombooks@yahoo.co.in

visit us at [http : // www.dotcombooks4u.com](http://www.dotcombooks4u.com).

The Publisher is not responsible for any omission or error though every care has been taken while preparing, printing, composing and proof reading of the Book. As all the Composing, Printing, Publishing and Proof Reading etc., are done by Humans, any and chances of Human Error could not be denied.

₹ 160.60

OPERATIONS RESEARCH TECHNIQUES FOR MANGEMENT

New Edition: 2020-21

© Reserved with the publishers only.

All rights reserved by Dotcom Publication. No part of this book is to be reproduced or transmitted in any form, Electronic, Mechanical, Photography or nay information stored in a retrieved system without prior permission in writing from Dotcom Publications, nor be otherwise circulated in any form of binding or cover other than that in which it is published without a similar condition being imposed on the subsequent purchaser.

This book is meant for education and learning purposes. The author(s) of the book has/have taken all reasonable care to ensue that the contents of the book do not violate any existing copyright or other intellectual rights of any person in any manner whatsoever. In the event the author(s) has/have been unable to track any source and if any copyright has been inadvertently infringed, please notify the publisher in writing for corrective action.